

LUNA2000-100KTL-M1 Smart Power Control System

Quick Guide

Issue: 03
Part Number: 31500HTE
Date: 2023-06-10

HUAWEI TECHNOLOGIES CO., LTD.



NOTICE

- Before installing the equipment, read the user manual carefully to get familiar with product information and safety precautions. The product warranty does not cover equipment damage caused by failure to follow the storage, transportation, installation, and usage guidelines specified in this document and the user manual. Scan the QR code near the nameplate to view the user manual and safety precautions.
- The information in this document is subject to change without notice. Every effort has been made in the preparation of this document to ensure accuracy of the contents, but all statements, information, and recommendations in this document do not constitute a warranty of any kind, express or implied.
- The **Danger**, **Warning**, **Caution**, and **Notice** statements described in this document do not cover all the safety precautions. You also need to comply with relevant international, national, or regional standards and industry practices.
- Only qualified professionals or trained personnel are allowed to perform operations on the equipment. Operation personnel shall understand the system, its working principles, and relevant national/regional standards.
- During operations, use dedicated insulated tools and wear personal protective equipment, such as protective clothing, insulated shoes, goggles, safety helmets, and insulated gloves.

1 Overview

Appearance

Smart Power Control System
(also referred to as Smart PCS)

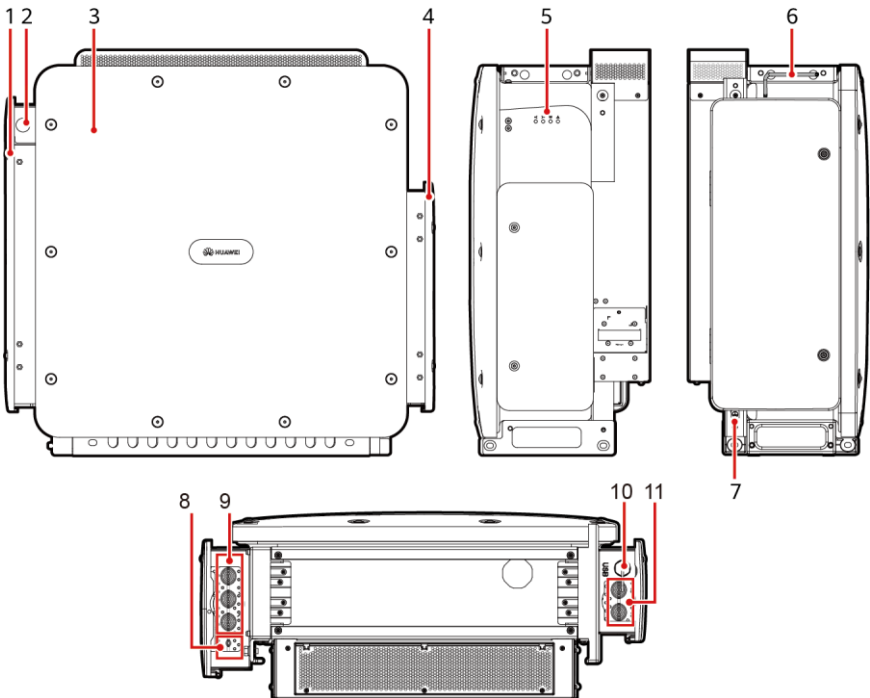

IB02W00001

- (1) AC maintenance compartment (2) Communications cable hole (FE) (3) Panel
- (4) DC maintenance compartment (5) LED indicator (6) Security Torx wrench
- (7) Protective ground point (8) Communications cable hole (COM) (9) AC power cable hole
- (10) USB port (USB) (11) DC power cable hole

Dimensions and Weight

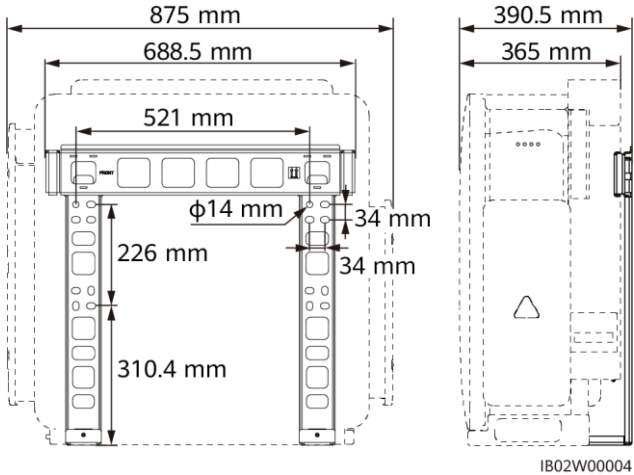

Smart PCS: < 95 kg
 Mounting bracket: 6.09 kg

Installation Scenarios

Scenario	Mounting Bracket	Moving Tool
Installed on the Smart String Energy Storage System (ESS)	Mounting bracket, M12 bolt assemblies	Lifting handles or crane (with lifting rope)

Notes:

- The LUNA2000-100KTL-M1 can be installed only on the LUNA2000-200KWH-2H1 Smart String ESS.
- The crane (with lifting rope) is prepared by the customer (lifting capacity ≥ 2 t, operating radius ≥ 2 m, length of the lifting rope ≥ 1.8 m). To prevent damage to the device surfaces, do not use metal lifting ropes such as steel ropes.
- The mounting brackets (including M12 bolt assemblies) are delivered with the device.
- Lifting handles can be purchased from the Company based on the installation and transportation methods.

2 Installation Process

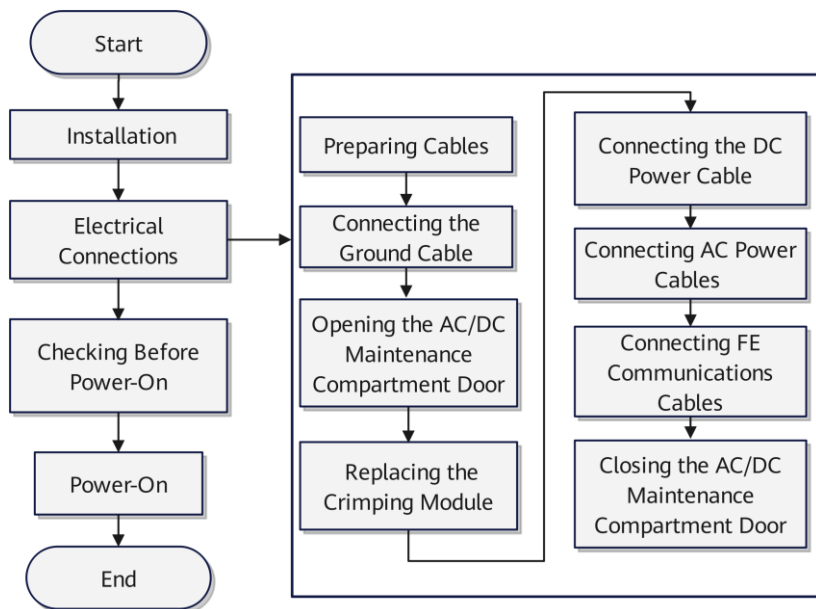

3 Installing the Smart PCS

1. Install the mounting bracket.

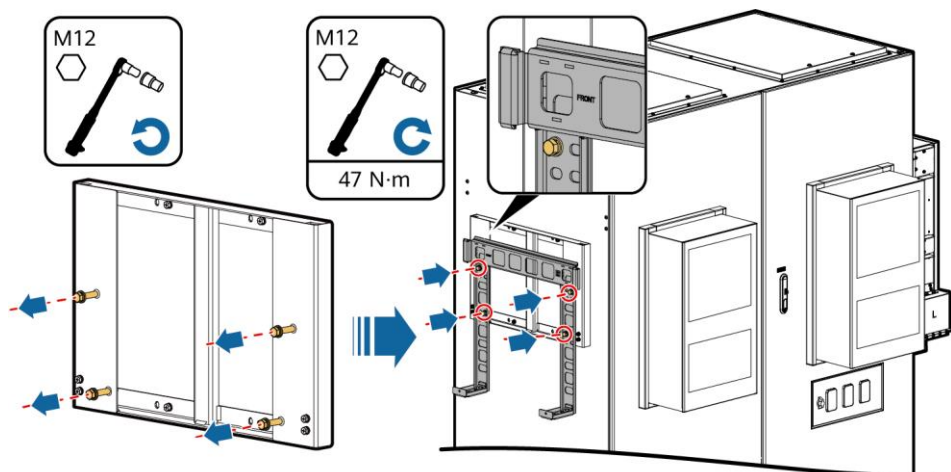

IB02H00044

2. Install mounting ears.

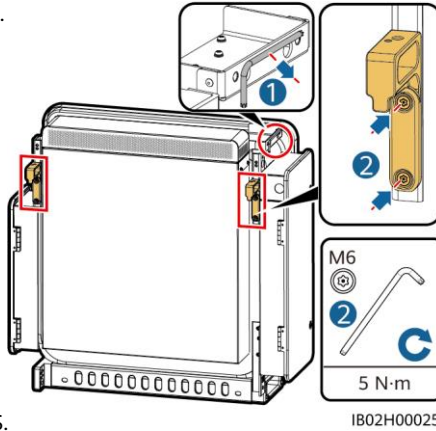

3. Move the Smart PCS.

Manual Handling

CAUTION

Ensure that the lifting handles are installed to the correct screw holes. Do not install them to the mounting bracket screw holes on the top. Incorrect installation may cause device damage or personal injury.

NOTICE

Four persons or appropriate transportation tools are required to move the Smart PCS.

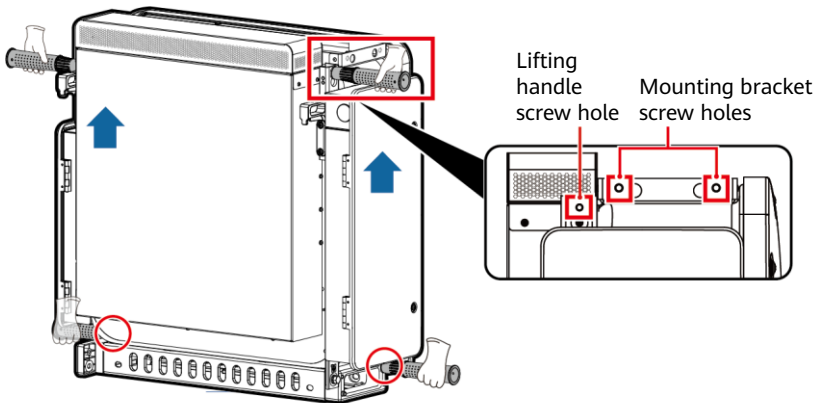

NOTICE

- Secure the lifting handles (with the steel washers of the lifting handles closely fitted to the battery pack).
- If the stud of a lifting handle is bent, replace the lifting handle in time.

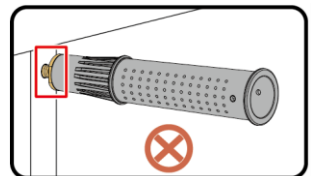
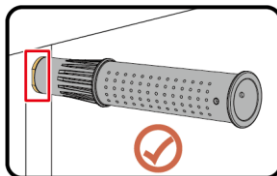

5000004

Hoisting



Do not walk under hoisted objects.

Slowly and steadily hoist and position the Smart PCS to avoid bumping and damaging the device enclosure.

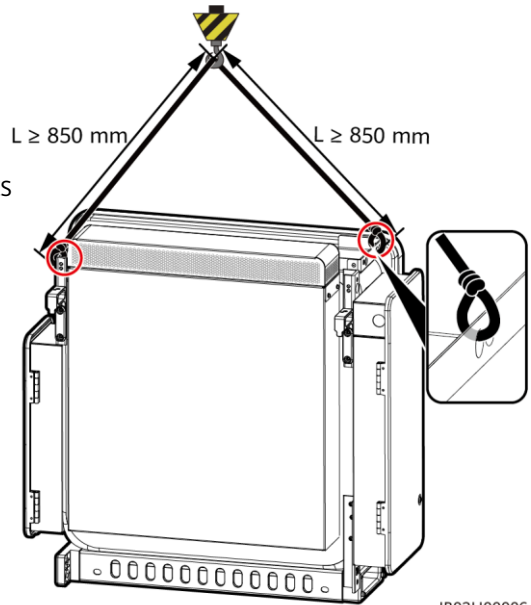

IB02H0006

4. Install the Smart PCS to the mounting bracket.

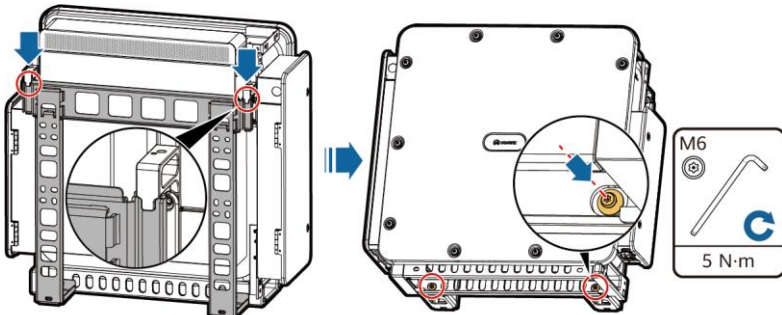

IB02H0007

4 Electrical Connections



- Remove the rubber rings according to the cable diameter range, and ensure that the crimping module is not damaged. Otherwise, the device may fail to offer the expected level of protection.
- Ensure that the AC/DC power cables are connected securely. Otherwise, the Smart PCS may fail to operate, or become overheated during operation due to an unreliable connection, which will damage the terminal block.

NOTICE

Do not pull the cables horizontally after they have been secured, as this may damage the wiring terminals.

4.1 Preparing Cables

NOTE

- The cable diameters must comply with local standards.
- The factors that affect cable selection include the rated current, cable type, routing mode, ambient temperature, and maximum expected line loss.

Cable	Type	Conductor Cross-Sectional Area Range	Outer Diameter	Source
Ground cable	Single-core outdoor copper cable and M10 OT/DT terminal	$S_p \geq S/2^{[1]}$ (S indicates the conductor cross-sectional area of the AC power cable.)	-	Prepared by the customer
AC power cable (either one)	(Recommended) Three-core (L1, L2, L3) outdoor cable and M12 OT/DT terminal (L1, L2, L3)	70–240 mm ²	30–65 mm	
	Single-core outdoor cable and M12 OT/DT terminal	70–240 mm ²	15–35 mm	
DC power cable	Prefabricated DC power cable (with a corrugated pipe)	50 mm ²	25 mm	Delivered with the ESS
FE communications cable	CAT 5E outdoor shielded network cable (internal resistance ≤ 1 ohm/10 m) and the shielded RJ45 connector	0.2–0.25 mm ²	6.5–7.1 mm	The cable delivered with the device is 1.2 m long. You can also prepare a cable according to site requirements.

Note [1]: The value is valid only if the conductors of the ground cable and AC power cable use the same material. If the materials are different, ensure that the conductor cross-sectional area of the ground cable produces a conductance equivalent to that of the area $S/2$. The specifications of the ground cable are subject to this table or calculated according to IEC 60364-5-54.

4.2 Connecting the Ground Cable

NOTE

- It is recommended that the Smart PCS be connected to a nearby ground point. The ground points of all Smart PCSs in the same array must be connected to ground cables.
- The ground point in the AC maintenance compartment serves only as the equipotential connection point of the protective ground point, and cannot replace the protective ground point of the chassis shell.

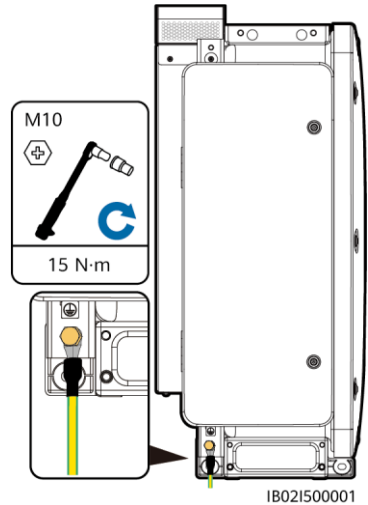

4.3 Opening the AC/DC Maintenance Compartment Door

WARNING

- Do not open the panel of the Smart PCS.
- Before opening the maintenance compartment door of the Smart PCS, turn off the external switches on the AC and DC sides.
- Do not open the maintenance compartment door on rainy or snowy days.

NOTE

The following describes how to open the maintenance compartment door on the DC side. The procedure for opening the maintenance compartment door on the AC side is the same.

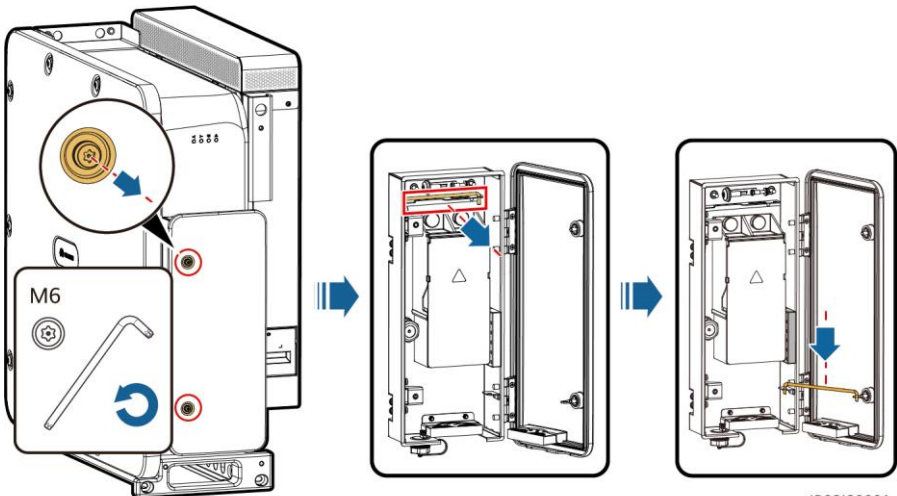

4.4 Replacing the Crimping Module

NOTE

- If the AC power cable is a multi-core cable, replace the crimping module.
- If the crimping module does not need to be replaced, remove it and keep it properly.

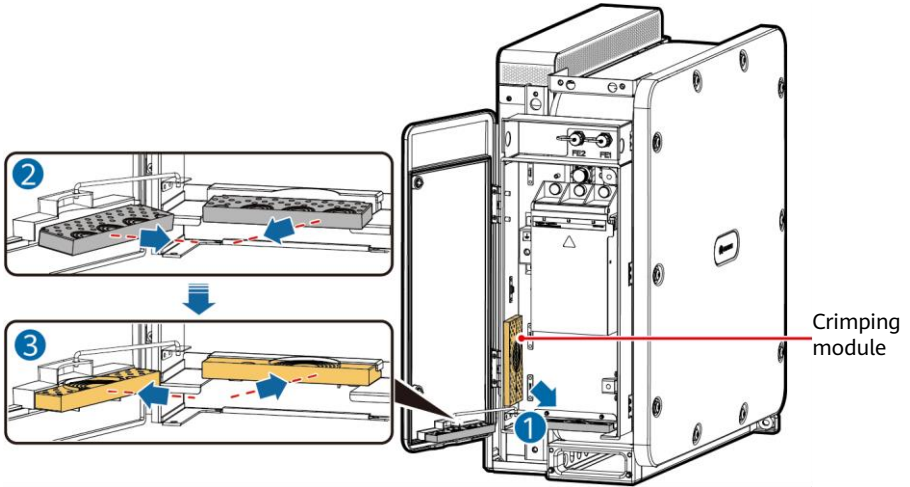

S000007

4.5 Connecting DC Power Cables

WARNING

Before connecting DC power cables, check and label the polarity of the cables.

1. The prefabricated DC power cables (with corrugated pipes) are delivered with the ESS. Remove the rubber ring based on the cable diameter range.
2. Connect the DC power cables to the terminal block and ensure that the cables are securely connected.

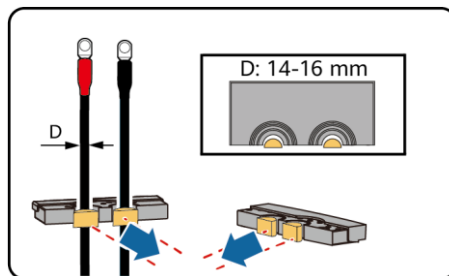

S000006

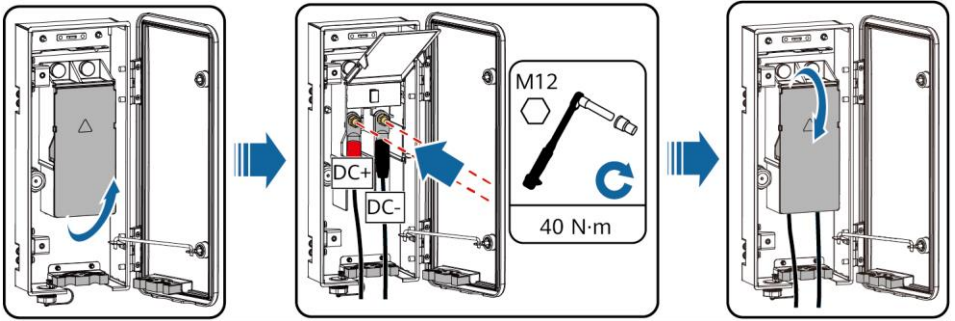

S000005

4.6 Connecting AC Power Cables

Single-core Cable Connection Method

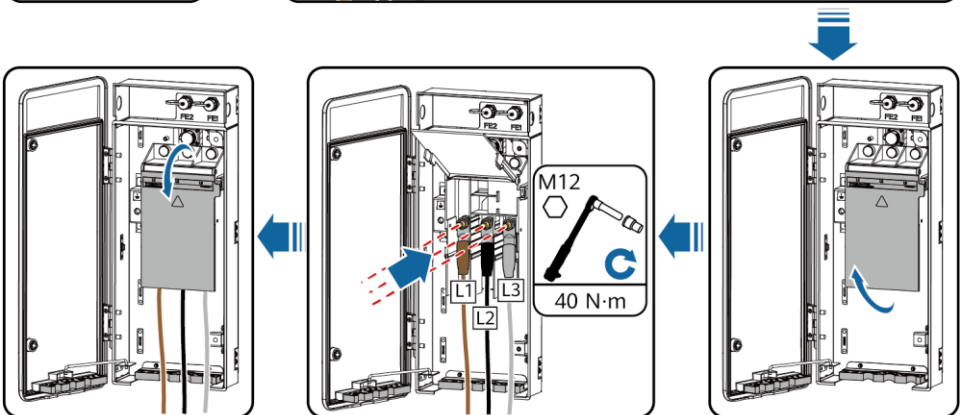
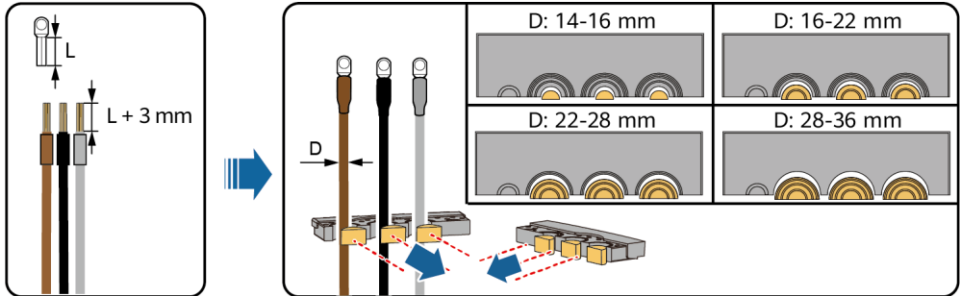
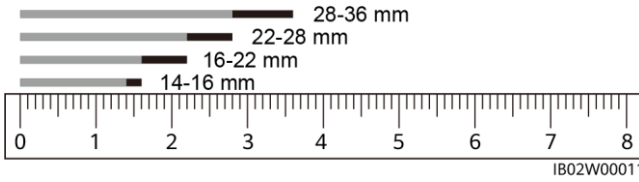

IB02I20003

Three-core Cable Connection Method

NOTE

- It is recommended that the stripped length of the L2 wire be 15 mm shorter than that of the L1 or L3 wire.
- If a cable has a jacket, ensure that the jacket is in the maintenance compartment.

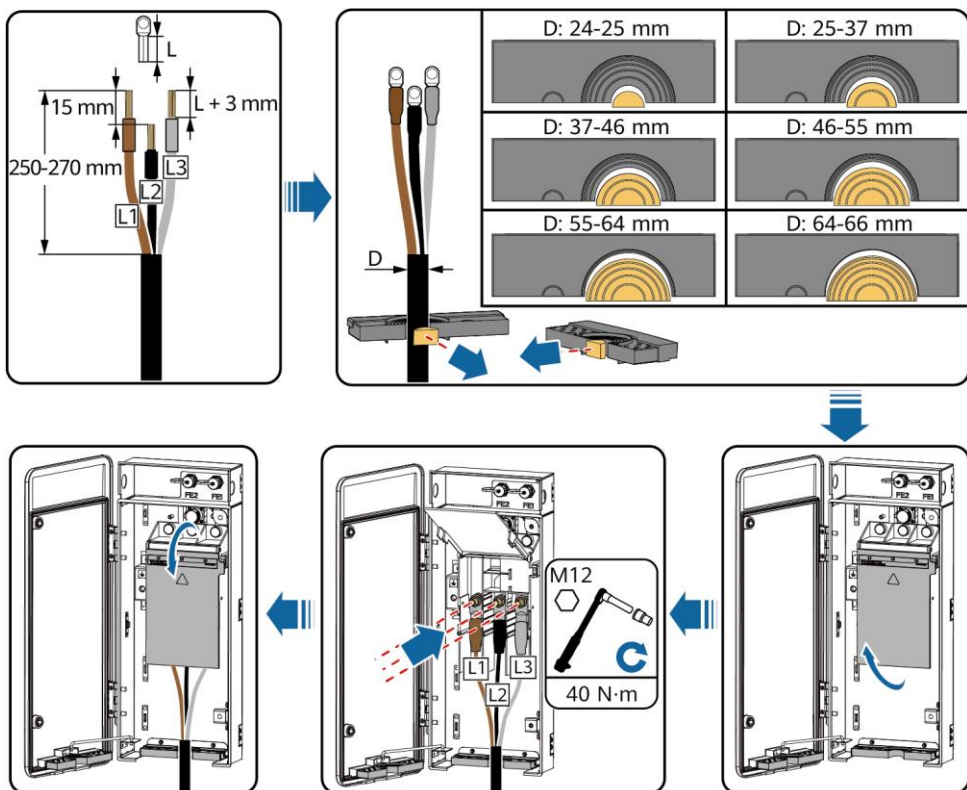
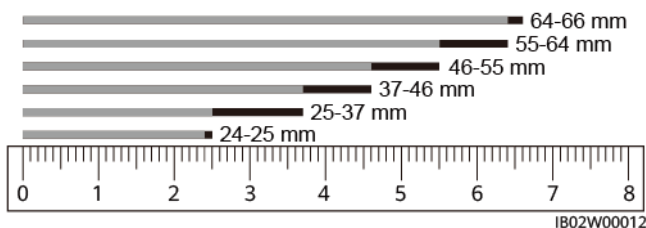

4.7 Connecting FE Communications Cables

NOTICE

- The Smart PCS is connected to the SmartModule through FE communications cables. Ensure that both ends are connected to GE2 and GE3 of the SmartModule.
- For multiple Smart PCSs, connect all Smart PCSs in hand-in-hand mode through FE communications cables into a ring network.

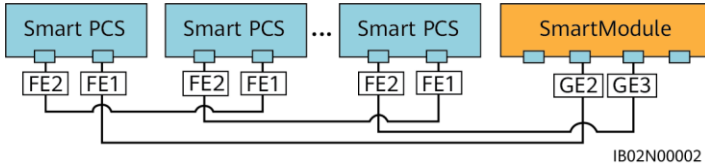

1. Prepare the FE communications cables.

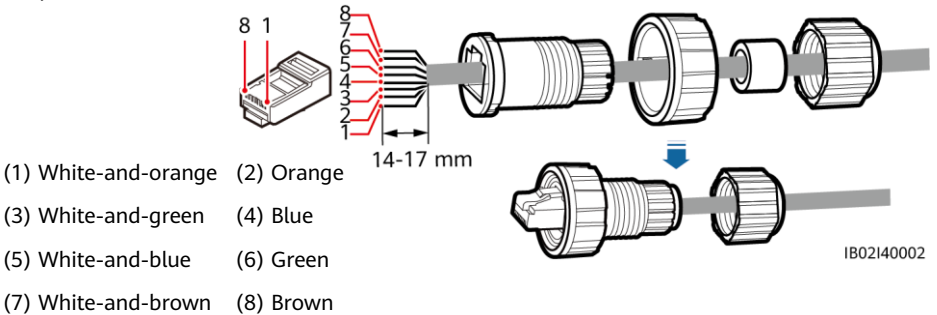

2. Connect the FE communications cables.

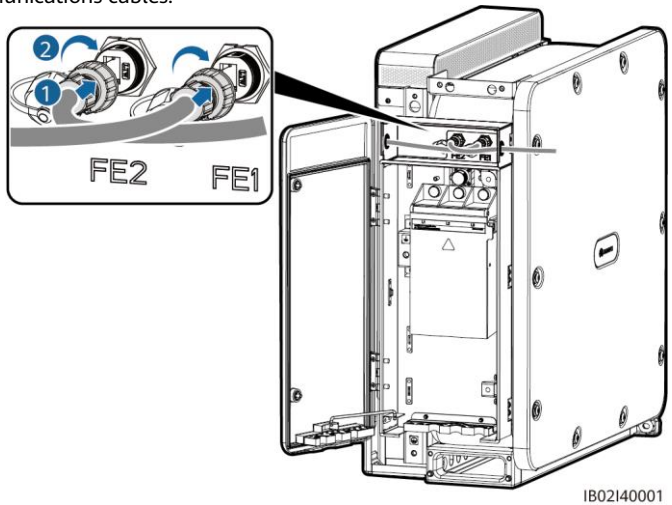

4.8 Closing the AC/DC Maintenance Compartment Door

NOTE

The following describes how to close the maintenance compartment door on the DC side. The procedure for closing the maintenance compartment door on the AC side is the same.

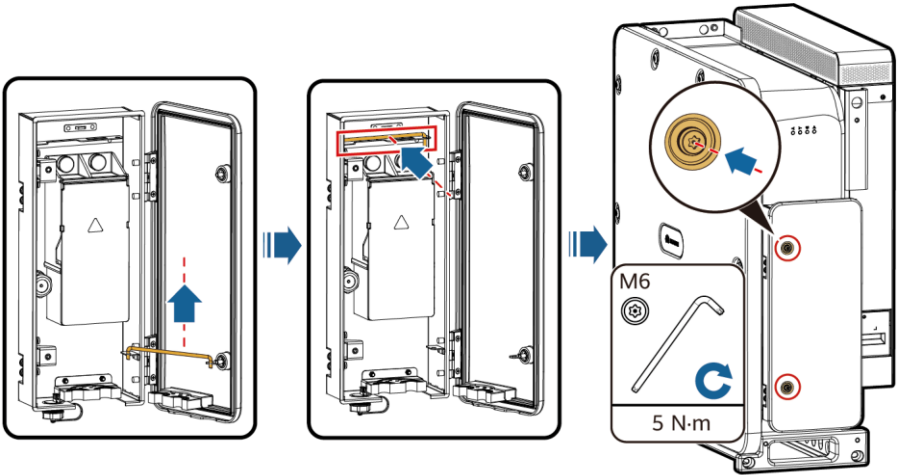





IB02130005

5 Checking Before Power-On

No.	Check Item
1	The Smart PCS is not deformed or damaged.
2	The Smart PCS is properly installed.
3	The clearance around the Smart PCS meets requirements.
4	The external switches on the AC and DC sides are in the OFF position.
5	All cables are intact and free from any damage or cracks.
6	All ground cables are connected securely and reliably.
7	All AC power cables are connected correctly and securely, and no open circuits or short circuits occur.
8	All DC cables are connected securely in correct polarity, and no open circuits or short circuits occur.
9	The communications cables are connected correctly and securely.
10	The crimping module is installed securely.
11	The AC maintenance compartment is clean and tidy.
12	The DC maintenance compartment is clean and tidy.
13	The AC maintenance compartment door is closed and the screws on the door are tightened.

No.	Check Item
14	The DC maintenance compartment door is closed and the screws on the door are tightened.
15	The waterproof plugs on the unused USB, COM, and FE ports are secured.

6 Power-On

Category	Indicator Status (Blinking Fast: On for 0.2s and Off for 0.2s; Blinking Slowly: On for 1s and Off for 1s.)	Description
DC indication 	Steady green	The DC side is properly connected, and the auxiliary power inside the device is working.
	Blinking green slowly	The device is in standby or cable connection detection state.
	Blinking red fast	An environmental fault occurs on the DC side.
	Off	The DC side is not properly connected, or the auxiliary power inside the device is not working.
Running indication 	Steady green	The device is operating in grid-tied mode.
	Blinking green slowly	The system environment is normal and the device is not in the working state.
	Blinking red fast	An environmental fault occurs on the AC side.
	Off	The AC side is not connected to the power grid.
Communication indication 	Blinking green fast	The device receives data through the northbound FE ports.
	Off	The device has not received data through the FE ports in at least 10s.
Fault/Maintenance indication 	Steady red	A major alarm is generated on the device.
	Blinking red fast	A minor alarm is generated on the device.
	Blinking red slowly	A warning is generated on the device.
	Blinking green slowly	The device is under local maintenance or shuts down after receiving a command.
	Off	No alarm is generated, and no local maintenance operations are performed.

NOTICE

Before turning on the AC switch between the Smart PCS and the power grid, check whether the AC voltage is within the required range by using a multimeter. (See the local power grid standard.)

1. Turn on the AC switch between the AC side of the Smart PCS and the power grid.
2. Turn on the DC switches between the DC side of the Smart PCS and the ESS.
3. Use the SUN2000 app, SmartLogger, or management system to deliver a startup command and wait for the system to soft start.
4. Observe the LED indicators to check the running status of the Smart PCS.

NOTE

For details about deployment commissioning, see the *Commercial and Industrial Microgrid Energy Storage Solution Quick Guide*.

Huawei Technologies Co., Ltd.
Huawei Industrial Base, Bantian, Longgang
Shenzhen 518129 People's Republic of China
solar.huawei.com